



DIONICS, INC.

65 Rushmore Street
Westbury, NY 11590

Phone: (516) 997-7474

Fax: (516) 997-7479

Website: www.dionics-usa.com

DIG-11-15-30-DD MOSFET Drivers With Dynamic Discharge*

*US Patent 4,931,656

Features:

- Fast Turn Off, Active Gate Discharge
- Dielectrically Isolated
- Logic Circuit Compatibility
- High Open Circuit Voltage Up To 15V
- High Operating Temperature
- Fast Response Time
- High Isolation Resistance
- Excellent Input/Output Linearity
- Self Limiting Gate Voltage

Applications:

- Gate Drive For MOS devices
- Gate Drive For SCR
- Solid-State Relays
- Interface Between Logic Circuits & External Loads
- A.T.E. (Automatic Test Equipment)
- Switching Equipment
- Isolation Amplifiers
- Load Control From Microprocessor I/O Ports
- Thermocouple Open Detectors

Description:

The photovoltaic MOSFET driver is a State-of-the-Art, optically coupled floating power source used primarily to control MOSFETs when electrical isolation between input and output is required.

In addition to the infrared LED and photovoltaic diode array, each of the DD (Dynamic Discharge) products contains circuitry that rapidly discharges the power MOSFET gate when the LED is deactivated. The unique rapid discharge features of the photovoltaic MOSFET drivers make them particularly useful for high side switching of N-channel MOSFETs in solid-state relays, DC motor control and switching regulator applications.

The typical input circuit to the LED is a limiting resistor connected in series with the LED. When activated, the LED emits infrared light towards the photovoltaic diode array, which then responds by generating an open circuit voltage (V_{oc}) and disabling the turn off circuitry. The self-limiting photovoltaic output of the diode array is floating and therefore, can be safely applied directly to the gate and source of a MOSFET, regardless of the source potential of the MOSFET. When the LED is deactivated, the active turn off circuit discharges the capacitive input of the MOSFET. The active turn off circuitry is designed such that the turn off time of the MOSFET is relatively independent of the input capacitance of the MOSFET over a range of 300 to 5000 pF. Standard packages include low cost plastic mini-dips and hermetic 8-pin DIP ceramic side brazed.

<i>Pin Designation</i>	
Pin Number	DIG-11-15-30-DD
1	Input +
2	Input -
3	N.C
4	N.C
5	N.C
6	Output +
7	N.C
8	Output -

❖ Equivalent Circuit:

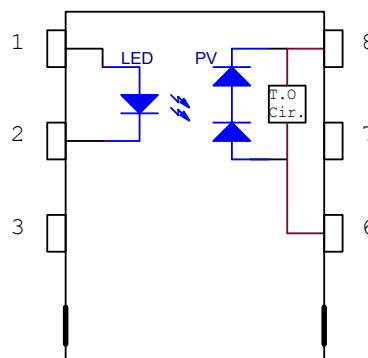

❖ Package Layout:

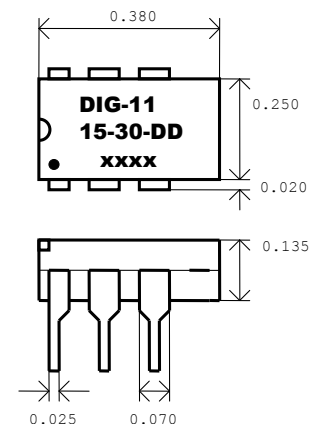

DIG-11-15-30-DD MOSFET Drivers With Active Dynamic Discharge

❖ Absolute Maximum Ratings (T_a = 25 °C)		
LED Forward Current	Steady State	100 mA
LED Forward Current	Peak 10% Duty Cycle	150 mA
LED Reverse Voltage		10V
Output Discharge Current		15mA
Operating Temperature Range	Plastic D.I.P	-40 to 85 °C
Operating Temperature Range	Side Braze D.I.P	-50 to 125 °C
Storage Temperature		-50 to 125 °C
Power Dissipation		100 mW

❖ Electrical Characteristics (T_a =25 °C Unless otherwise specified)

<i>Model Number</i>	<i>DIG-11-15-30-DD</i>			<i>Unit</i>	
Parameter & Test Condition	Symbol	Min.	Typ.	Max.	
Open Circuit Voltage	V_{oc}				
I _{Ied} = 2mA			14.5		V
I _{Ied} = 10mA		14.0	14.8	16.0	V
I _{Ied} = 30 mA; 50% Duty Cycle		14.5	15.0	16.0	V
Short Circuit Current	I_{sc}				
I _{Ied} = 2mA			8.0		μA
I _{Ied} = 10mA		10.0	20.0	-	μA
I _{Ied} = 30 mA; 50% Duty Cycle		30.0	60.0	-	μA
LED Forward Voltage	V_r				
I _f = 20mA		-	1.3	1.7	V
LED Reverse Current	I_r				
V _r = 5V		0.1	10.0	-	μA
Off State Voltage	V_{off}				
I _{off} = 10μA; I _{Ied} = 0mA		-	0.65	0.75	V
Isolation Voltage	V_{iso}	2500	-	-	VDC
Temp. Coefficients	⊖ V	-	60	-	mV / °C
	⊖ I	-	0.5	-	%I / °C
Turn-On Time	T_{on}				
I _{Ied} = 30 mA		-	100	-	μs
C=1500pF; V _{oc} to 50%					
Turn-Off Time	T_{off}				
I _{Ied} = 30 mA		-	3.0	6.0	μs
C=1500pF; V _{oc} to 50%					

Typical Applications

Power MOSFET Photovoltaic SPST N/O Relays With Short Circuit Protection

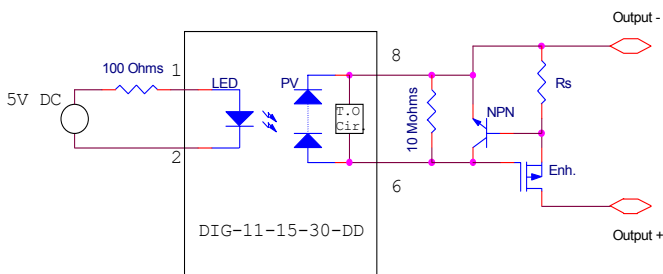

Power MOSFET Photovoltaic SPST N/O AC-DC Relays

