



DIONICS-USA INCORPORATED

96-B Urban Avenue
Westbury, NY 11590

Phone: (516) 997-7474

Fax: (516) 997-7479

Website: www.dionics-usa.com

DIH-134 Power MOSFET Dual N/O SPST Photovoltaic DC Relay

Features:

- Package Contains Two N/O DC Relays;
- Fast Switching Speeds
- Optically Isolated to 400V DC.
- Immune to False Triggering
- Small size, Hermetic 8-pin SIP Package
- Designed to Meet MIL-R28750 and 28V DC System Surge and Spike Requirement of MIL STD-704.
- Y-Level MIL-Screening Available (**DIH-134Y**)

Applications:

- Replacement of Mechanical Relays
- Motor Control & Power Control
- Aircraft Flight Control Systems
- A.T.E (Automatic Test Equipment)
- Load Control From Processor I/O Ports
- Power Supply Circuits
- Medical Electronics

Description:

The DIH-134 is a State-of-the-Art Photovoltaic Solid State Relay designed for 28V DC Aircraft power applications where speed, current overload protection and immunity to transient voltages are critical.

The DIH-134 contains current limiting networks and thermally sensitive integrated circuits that disable the output, if the output MOSFETs approach an unsafe operating temperature. Because the thermally sensitive integrated circuits have built-in hysteresis, the output MOSFETs are automatically restarted when a safe temperature is reached. This auto restart feature eliminates the need for system restart signals. If the overload condition continues to exist, the cycle is repeated; if the overload condition is removed, the relay returns to normal operation.

The package contains two independent N/O relays, with separate LED inputs and optically isolated power MOSFET outputs. Each relay, A or B, is capable of carrying 350mA DC continuous current and 500mA DC peak current. Each LED optically couples to a Photovoltaic (PV) IC chip which responds by generating a voltage. This voltage is internally connected to the Gate and Source terminals of the output MOSFETs, thus controlling their current. The DIH-134 is also available screened to military specifications, as required.

Pin Designations

<i>Relay A</i>		<i>Relay B</i>	
1	Input +	5	Input +
2	Input -	6	Input -
3	Output -	7	Output -
4	Output +	8	Output +

* DIH-134 Equivalent Circuit

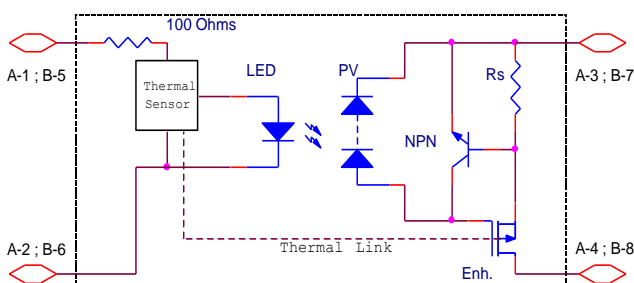

* Package Layout:

Weight 1.5 Grams

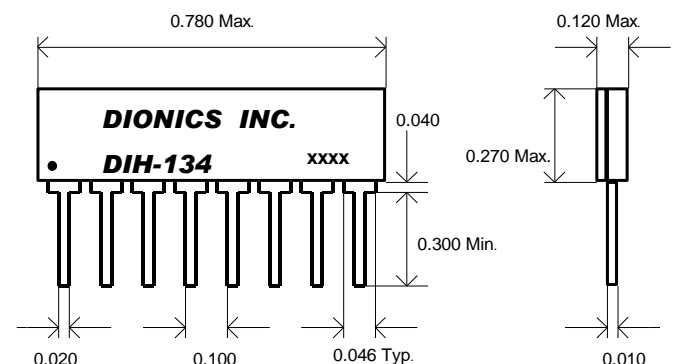

DIH-134: Power MOSFET Dual N/O SPST Photovoltaic DC Relay

Electrical Characteristics (Per Relay @ 25 °C unless otherwise specified):

- ❖ Relay A: Normally Open (N/O)
- ❖ Relay B: Normally Open (N/O)

❖ Input Characteristics

Symbol	Parameter	Min.	Typ.	Max.	Unit
I_{in}	Input Current	5.0	15.0	24.0	mA
V_{in}	Input Voltage Drop	1.3	—	1.5	V
$V_{rev.}$	Reverse Voltage	—	—	10.0	V
V_{on}	On State Voltage	3.5	—	—	V
V_{off}	Off State Voltage	—	—	1.5	V

❖ Output Characteristics

Symbol	Parameter	Typ.	Max.	Unit	Condition
I_{load}	Load Current	—	350 / 500	mA	Continuous / Peak
R_{on}	On Resistance @ $T_a = 85\text{ }^\circ\text{C}$	—	3	Ω	$I_{in}=18\text{ (mA)}$; $I_{load} = 100\text{mA}$
		—	4	Ω	$I_{in}=18\text{ (mA)}$; $I_{load} = 100\text{mA}$
I_{leak}	Leakage Current	—	10	μA	$V_{op}=75\text{ (V)}$
R_{iso}	Input/Output Resistance	10^8	—	Ω	
V_{op}	Operating Voltage	28	30.3	VDC	Limited by Power Dissipation
BV	Breakdown Voltage	—	80	VDC	At 100 μA
T_{on}	Turn-On Time	150	300	μs	$V_{in} = 4.5\text{V}$, P.W* = 100 μs ; $V_{op} = 30\text{V}$
T_{off}	Turn-Off Time	150	300	μs	$V_{in} = 4.5\text{V}$, P.W = 100 μs ; $V_{op} = 30\text{V}$
V_{iso}	Input-Output Isolation	—	400	V	DC
P	Maximum Power Dissipation	—	400	mW	In Free Air

PW*: Pulse Width.

❖ Timing Diagram

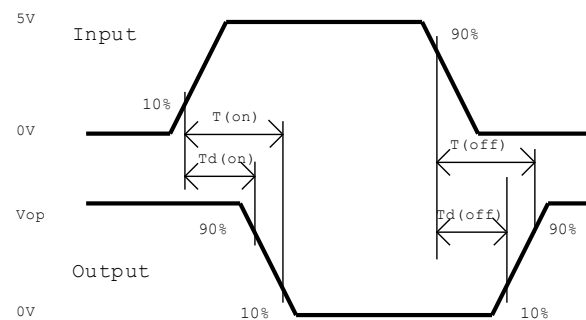

❖ Environmental Ratings:

- Storage Temperature: -25°C to $+125^\circ\text{C}$
- Constant Acceleration: 5000G
- Hermeticity: + Gross 1×10^{-5} atm cc/sec
+ Fine 5×10^{-8} atm cc/s **

** When screened to MIL-Specs.