



DIONICS, INC.

65 Rushmore Street
Westbury, NY 11590

Phone: (516) 997-7474

Fax: (516) 997-7479

Website: www.dionics-usa.com

DIH-137 Power MOSFET Dual N/C SPST Photovoltaic AC-DC Relay

Features:

- Package Contains Two N/C AC-DC Relays;
- Fast Switching Speeds
- Optically Isolated to 400V DC.
- Low Level Logic Compatibility
- Immune to False Triggering
- Small size, Hermetic 8-pin SIP Package
- Designed to Meet MIL-R28750 and 28V DC System Surge and Spike Requirement of MIL STD-704.

Applications:

- Replacement of Mechanical Relays
- Motor Control & Power Control
- Aircraft Flight Control Systems
- A.T.E (Automatic Test Equipment)
- Load Control From Processor I/O Ports
- Power Supply Circuits
- Medical Electronics

Description:

The DIH-137 is a State-of-the-Art Photovoltaic Solid State Relay designed for 28V AC-DC Aircraft power applications where package space-efficiency and high reliability are critical.

Each package contains two independent N/C relays, with separate LED inputs and optically isolated power MOSFET outputs. The Normally Closed (N/C) outputs are able to operate AC or DC.

Each relay, A or B, is capable of carrying 150mA DC continuous current and 250mA DC peak current. Each LED optically couples to a Photovoltaic (PV) IC chip which responds by generating a voltage. This voltage is internally connected to the Gate and Source terminals of the output MOSFETs, thus controlling their current. The DIH-137 is also available screened to military specifications, as required.

<i>Pin Designations</i>			
<i>Relay A</i>		<i>Relay B</i>	
1	Input +	5	Input +
2	Input -	6	Input -
3	Output	7	Output
4	Output	8	Output

* DIH-137 Equivalent Circuit

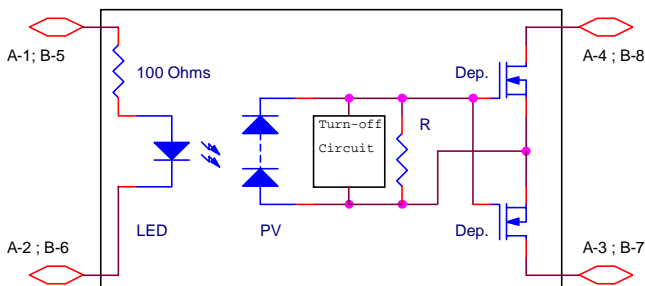

* Package Layout:

Weight 1.5 Grams

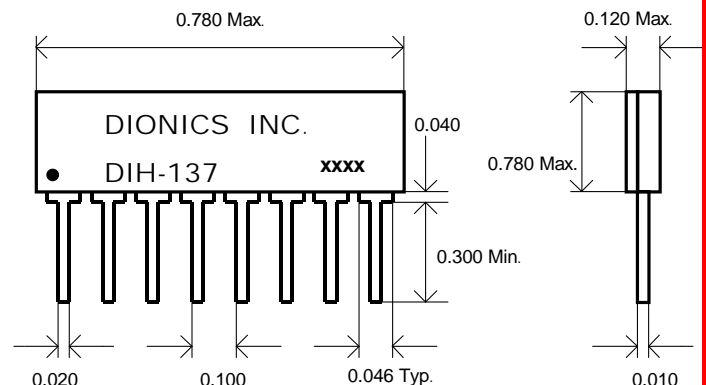

DIH-137: Power MOSFET SPST Photovoltaic AC-DC Relay

Electrical Characteristics (Per Relay @ 25 °C unless otherwise specified):

- ❖ Relay A: Normally Closed (N/C)
- ❖ Relay B: Normally Closed (N/C)

❖ Input Characteristics

Symbol	Parameter	Min.	Typ.	Max.	Unit
I_{in}	Input Current	5.0	15.0	24.0	mA
V_{in}	Input Voltage Drop	1.3	—	1.5	V
$V_{rev.}$	Reverse Voltage	—	—	10.0	V
V_{on}	On State Voltage	—	—	1.2	V
V_{off}	Off State Voltage	4.0	—	—	V

❖ Output Characteristics

Symbol	Parameter	Typ.	Max.	Unit	Condition
I_{load}	Load Current	—	150 / 250	mA	Continuous / Peak
R_{on}	On Resistance $T_c = 85\text{ }^\circ\text{C}$	—	18	Ω	$I_{in} = 0\text{ (mA)}$; $V_{op} = 80\text{ (V)}$
		—	28	Ω	$I_{in} = 0\text{ (mA)}$; $V_{op} = 80\text{ (V)}$
R_{iso}	Input/Output Resistance	10^8	—	Ω	
I_{leak}	Leakage Current	—	100	μA	$I_{in} = 18\text{ (mA)}$; $V_{op} = 80\text{ (V)}$
V_{op}	Operating Voltage	30	80	V	DC
BV	Breakdown Voltage	—	100	V	DC
T_{on}	Turn-On Time	150	300	μs	$V_{in} = 4.5\text{ V}$, P.W* = 100 μs ; $V_{op} = 30\text{ V}$
T_{off}	Turn-Off Time	150	300	μs	$V_{in} = 4.5\text{ V}$, P.W* = 100 μs ; $V_{op} = 30\text{ V}$
V_{iso}	Input-Output Isolation	—	400	V	DC
P	Maximum Power Dissipation	—	400	mW	

PW*: Pulse Width.

❖ Timing Diagram

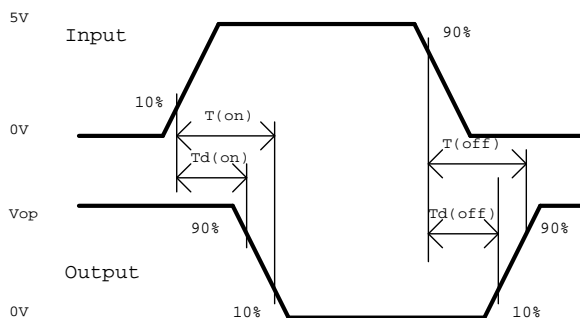

❖ Environmental Ratings:

- Operating Temperature $-40\text{ }^\circ\text{C}$ to $+85\text{ }^\circ\text{C}$
- Storage Temperature: $-40\text{ }^\circ\text{C}$ to $+125\text{ }^\circ\text{C}$
- Constant Acceleration: 5000G
- Hermeticity: + Gross 1×10^{-5} atm cc/sec
+ Fine 5×10^{-8} atm cc/s **

** When screened to MIL-Specs.