



DIONICS, INC.

65 Rushmore Street
Westbury, NY 11590

Phone: (516) 997-7474

Fax: (516) 997-7479

Website: www.dionics-usa.com

LEVEL-SHIFTED GAS DISCHARGE DISPLAY DIGIT DRIVERS

DI-507B

DI-512B

General Description:

The DIONICS DI-507B and DI-512B series circuits are designed for interfacing between MOS or TTL circuitry and gas discharge display panels. Each section of these devices is made up of a switched constant current level shifter-capable of high voltage operation and a PNP-NPN driver transistor pair. The constant current operation of the level shifter stage results in low power dissipation. Input circuitry is suitable for open drain PMOS, CMOS, open-collector or standard TTL.

Features:

- ✓ 125V Level Shift Capability
- ✓ MOS and TTL Compatibility
- ✓ 6- and 8-line Versions
- ✓ Low Power Dissipation
- ✓ Reliable Dielectric Isolation Process
- ✓ Pin For Pin Replacement for
Sprague UDN-6164A, UDN-6184A
- ✓ Functional Replacement For SIGNETICS 585 Series
- ✓

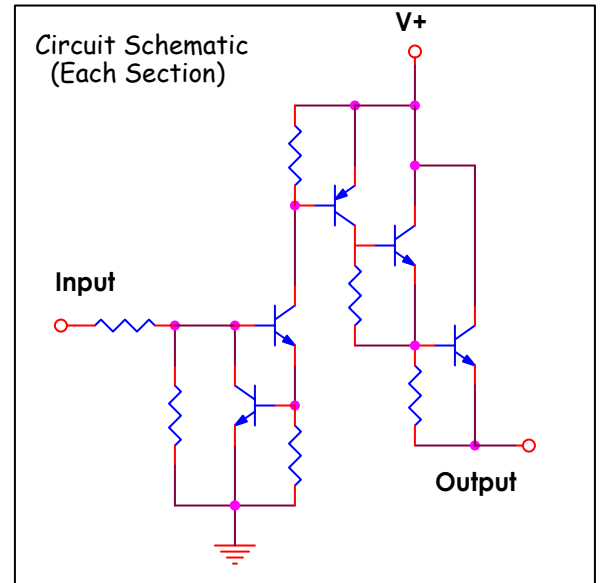

DI-507B

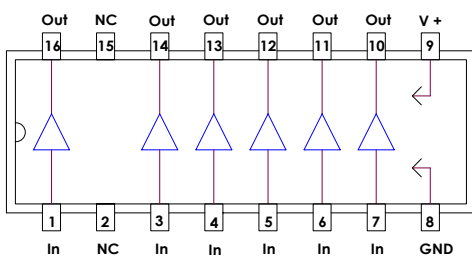
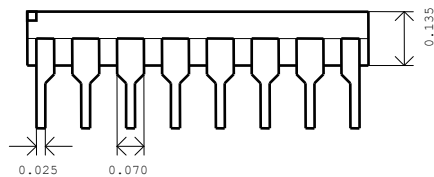
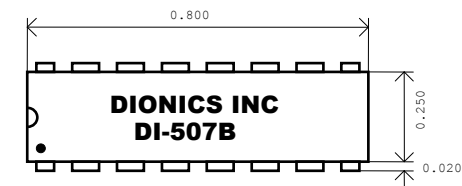

Package Layout:

DI-512B

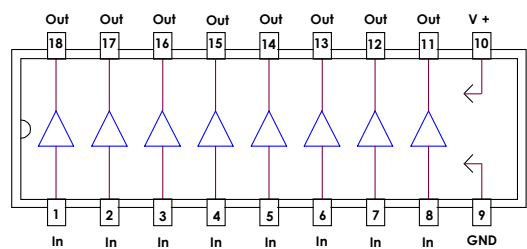
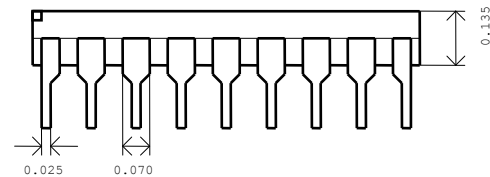
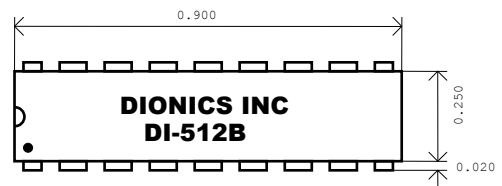

Absolute Maximum Rating ($T_a = 25\text{ }^{\circ}\text{C}$)

Characteristic	Symbol	Notes	Limits	Units
Supply Voltage	V +	Measured With Respect to GND	125	V
Input Voltage	V _{in}	Measured With Respect to GND	35	V
Output Voltage	V _{out}	Measured With Respect to V + Terminal	90	V
Output Current	I _{out}		40	mA
Power Dissipation DI-512B DI-507B	P _D	Derate at 8 mW/ $^{\circ}\text{C}$ Above 25 $^{\circ}\text{C}$ Ambient	800	mW
	P _D	Derate at 6 mW/ $^{\circ}\text{C}$ Above 25 $^{\circ}\text{C}$ Ambient	600	mW
Storage Temperature	T _s		-55 to +125	$^{\circ}\text{C}$
Operating Temperature	T _o		0 to +70	$^{\circ}\text{C}$

Electrical Characteristics ($T_a = 25\text{ }^{\circ}\text{C}$)

Parameter	Symbol	Notes	Conditions	Typ.	Max.	Units
Output Saturation Voltage	V _{out} (SAT)	V + = 100V; Measured With Respect to V+ Terminal	I _o = 25mA; V _i = 2.4V	3	10	V
Output Leakage Current	I _{out} (OFF)	V + = 180V	V _o = 90V; V _i = 0.4V	0.1	10	μA
Input Current	I _{in} (ON)		V _i = 2.4V	340	400	μA
Supply Current	I+	One Input at 2.4V, Others at 0.4V	V+ = 100V; V _i = 2.4 V; I _o = 0	0.5	1.5	mA

