



DIONICS-USA INCORPORATED

96-B Urban Avenue
Westbury, NY 11590

Phone: (516) 997-7474

Fax: (516) 997-7479

Website: www.dionics-usa.com

LEVEL-SHIFTED VACUUM FLUORESCENT DISPLAY DRIVERS

DI-503B

DI-504B

DI-508B

DI-509B

DI-513B

DI-514B

General Description:

The DIONICS DI-513B and DI-514B series circuits are designed for interfacing between MOS or TTL circuitry and vacuum fluorescent display panels. Each section of these devices consists of a switched constant current level shifter-capable of 50 Volt or 80 Volt- operation and a PNP-NPN driver transistor pair. The constant current operation of the level shifter stage results in low power dissipation. Input circuitry is suitable for open drain PMOS, CMOS, open-collector or standard TTL.

Features:

- ✓ 50V and 80V Level Shift Capability.
- ✓ MOS and TTL Compatibility
- ✓ 4 -, 6 - and 8-line Versions
- ✓ Segment and Digit Drivers
- ✓ Low Power Dissipation
- ✓ Reliable Dielectric Isolation Process

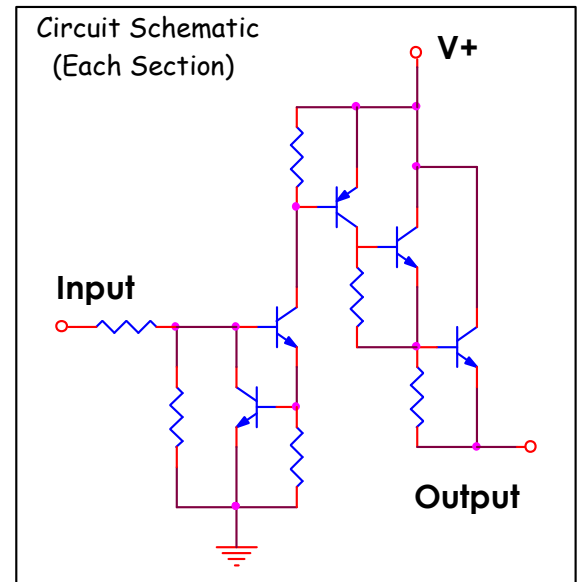

Package Layout:

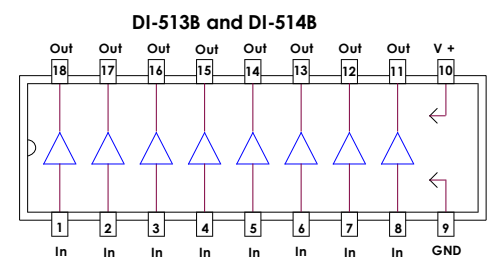
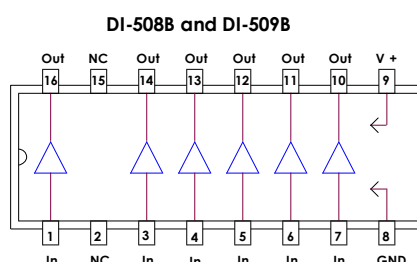
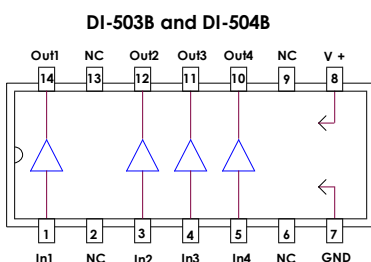
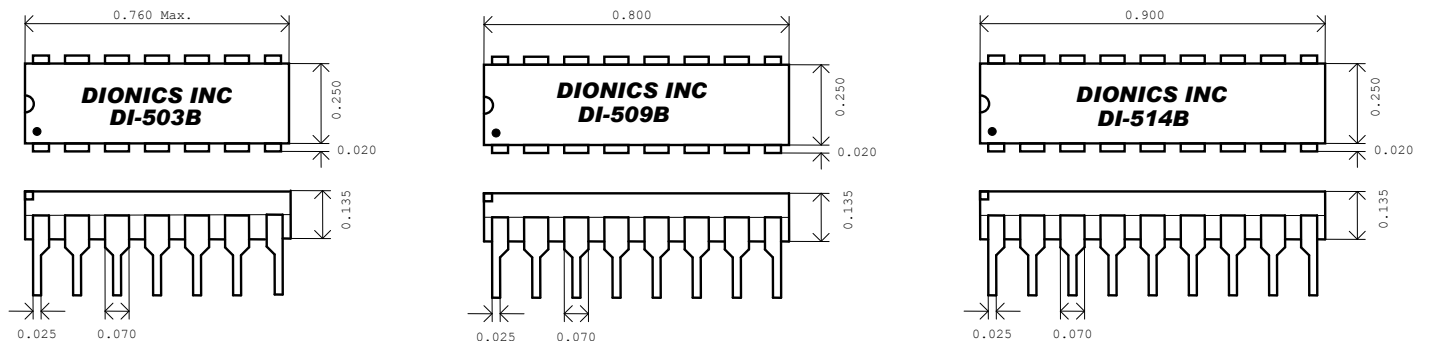

Absolute Maximum Rating (Ta = 25 °C)

Characteristic	Symbol	Notes	Limits		Units
			DI-504B DI-509B DI-514B	DI-503B DI-508B DI-513B	
Supply Voltage	V ₊	Measured With Respect to GND	50	80	V
Input Voltage	V _{in}	Measured With Respect to GND	35	35	V
Output Voltage	V _{out}	Measured With Respect to V ₊ Terminal	50	80	V
Output Current	I _{out}		30	30	mA
Power Dissipation:	P _D	Derate at DI-514B; DI-513B: 8 mW/°C Derate at DI-509B; DI-508B: 6 mW/°C Above 25°C Ambient	600	600	mW
Storage Temperature	T _s		-55 to 125		°C
Operating Temperature	T _o		0 to 70		°C

Electrical Characteristics (Ta = 25 °C)

Parameter	Symbol	Notes	Conditions	Typ.	Max.	Units
Output Saturation Voltage * DI-509B; DI-514B; DI-504B * DI-508B; DI-513B; DI-503B.	V _{out} (SAT)	Measured With Respect to V ₊ Terminal. V ₊ = 50V ----- V ₊ = 80V	I _o = 10mA; V _i = 2.4V	1.5	3	V
Output Leakage Current * DI-509B; DI-514B; DI-504B * DI-508B; DI-513B; DI-503B.	I _{out} (OFF)	V ₊ = 50V ----- V ₊ = 80V	V _o = 50V; V _i = 0.4V ----- V _o = 80V; V _i = 0.4V	0.1	10	μA
Input Current	I _{in} (ON)		V _i = 2.4V	250	400	μA
Supply Current	I ₊	One Input at 2.4V; Others at 0.4V.	V _i = 2.4 V; I _o = 0 V ₊ = 50V	0.8	1.2	mA

Typical Application:

